



## Floor console with nanoe™ X technology

### 1. Better air quality with nanoe™ X technology

- nanoe™ X technology with the benefits of hydroxyl radicals

### 2. Smart control

- Optional internet control via Panasonic Comfort Cloud app (requires CZ-TACG1)
- Compatible with Google Assistant and Amazon Alexa

### 3. Easy to integrate into your home

- Elegant and compact design

### 4. High comfort

- Super Quiet operation

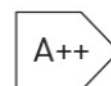



## Floor console with nanoe™ X technology

### 1. Better air quality with nanoe™ X technology

- nanoe™ X technology with the benefits of hydroxyl radicals

### 2. Smart control

- Optional internet control via Panasonic Comfort Cloud app (requires CZ-TACG1)
- Compatible with Google Assistant and Amazon Alexa

### 3. Easy to integrate into your home

- Elegant and compact design

### 4. High comfort

- Super Quiet operation

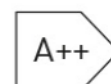



## Floor console with nanoe™ X technology

### Floor console. Efficient comfort and clean air all year round

The new Floor console has been designed to follow the high European demands. Because creating a comfortable home is not just about temperature. High efficiency A++, high comfort (Super Quiet technology only 20dB(A)) and better air quality combined in a breakthrough design.

### Built-in nanoe X Generator Mark 1



### Bringing nature's balance indoors

**nanoe™ X, technology with the benefits of hydroxyl radicals**  
Abundant in nature, hydroxyl radicals have the capacity to inhibit pollutants. nanoe™ X, technology can bring these incredible benefits indoors so that hard surfaces, soft furnishings, and the indoor environment can be a cleaner and pleasant place to be.

**7 effects of nanoe™ X – Panasonic unique technology**

- 1. Capacity to inhibit 5 types of pollutants:** Bacteria and viruses - Mould - Allergens - Pollen - Hazardous substances
- 2. Deodorises:** Odours
- 3. Moisturises:** Skin and hair

1



2



3

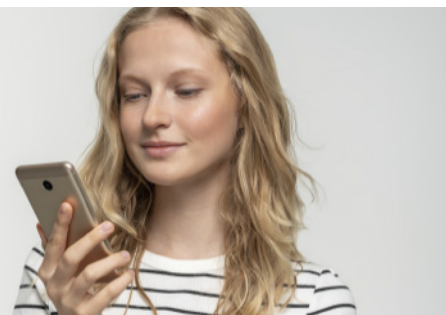

**nanoe™ X: improving protection 24/7**

Give the air conditioning the strength to increase the protection at home with nanoe™ X technology and convenient control via the Panasonic Comfort Cloud App. nanoe™ X works together with heating or cooling function when you are at home and can work independently when you are away.



## Floor console with nanoe™ X technology

### Floor console. Efficient comfort and clean air all year round

The new Floor console has been designed to follow the high European demands. Because creating a comfortable home is not just about temperature. High efficiency A++, high comfort (Super Quiet technology only 20dB(A)) and better air quality combined in a breakthrough design.

### Built-in nanoe X Generator Mark 1



nanoe™ X

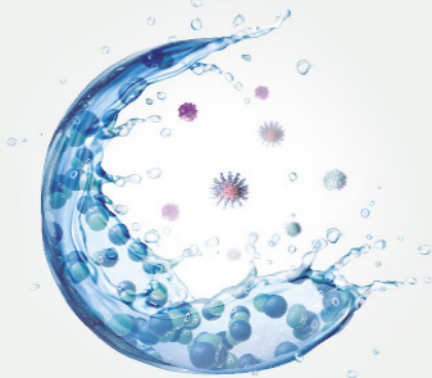

### Bringing nature's balance indoors

**nanoe™ X, technology with the benefits of hydroxyl radicals**  
Abundant in nature, hydroxyl radicals have the capacity to inhibit pollutants. nanoe™ X, technology can bring these incredible benefits indoors so that hard surfaces, soft furnishings, and the indoor environment can be a cleaner and pleasant place to be.

### 7 effects of nanoe™ X – Panasonic unique technology

1. **Capacity to inhibit 5 types of pollutants:** Bacteria and viruses - Mould - Allergens - Pollen - Hazardous substances
2. **Deodorises:** Odours
3. **Moisturises:** Skin and hair



### nanoe™ X: improving protection 24/7

Give the air conditioning the strength to increase the protection at home with nanoe™ X technology and convenient control via the Panasonic Comfort Cloud App. nanoe™ X works together with heating or cooling function when you are at home and can work independently when you are away.



## Technology for high comfort

### Easy to integrate into your home

A breakthrough design that integrates perfectly with any style. We have carefully selected materials and processes to create an elegant design. Compact in size and with a stylish design, the floor console will easily integrate into your home's interior decoration.

**There are four options available:**

**a. Floor installation. b. Wall installation. c. Half concealed. d. Concealed**

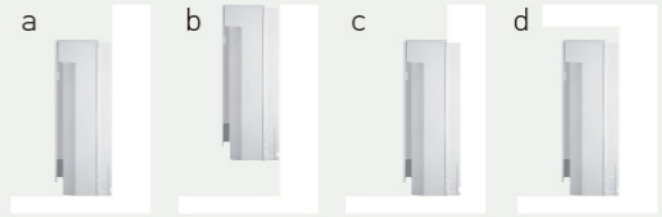

### The perfect solution for the replacement of old boiler heating systems

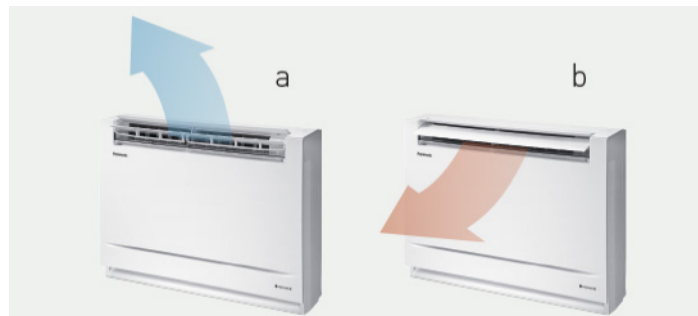

### Double air flow

Double air flow for improved comfort and temperature dispersion: through the top for an efficient operation.

**a. Cooling Mode. b. Heating Mode**



### Super Quiet operation

When the system reaches its set temperature, the unit will operate at only 20dB(A). Creating a comfortable home is not only by temperature - a quiet atmosphere is also important.



### iF Product Design Awards

**The iF Product Design Awards are among the most prestigious awards for product design excellence.**

Winning the award thanks to its highly intelligent functionality, the Panasonic Floor console is the ideal air-conditioning system for domestic and commercial applications.

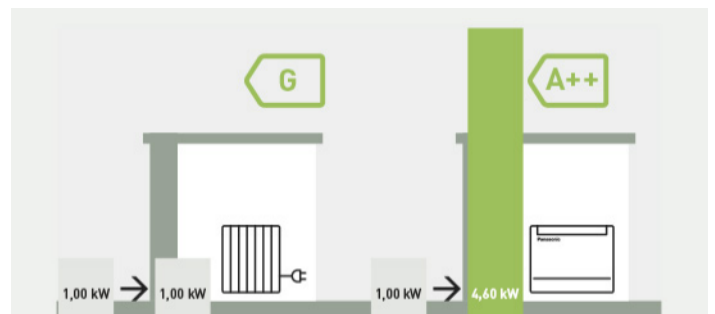

### High energy efficiency class A++

The floor console brings the outdoor heat energy inside. Can provide heat inside even when it is -15°C outside.

\* SCOP on heating mode for Floor console Type KIT-Z25-UFE and KIT-Z35-UFE compared with electrical heaters at +7°C.

## Technology for high comfort

### Easy to integrate into your home

A breakthrough design that integrates perfectly with any style. We have carefully selected materials and processes to create an elegant design. Compact in size and with a stylish design, the floor console will easily integrate into your home's interior decoration.

There are four options available:

a. Floor installation. b. Wall installation. c. Half concealed. d. Concealed

### The perfect solution for the replacement of old boiler heating systems

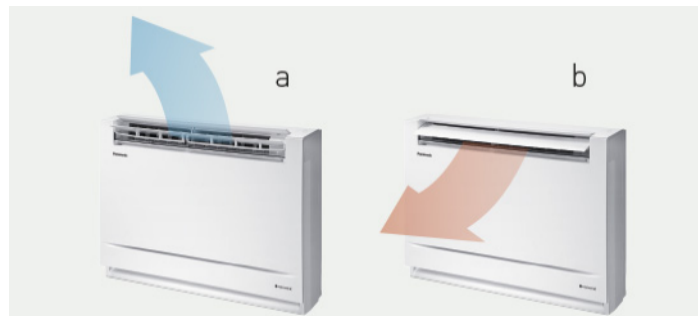
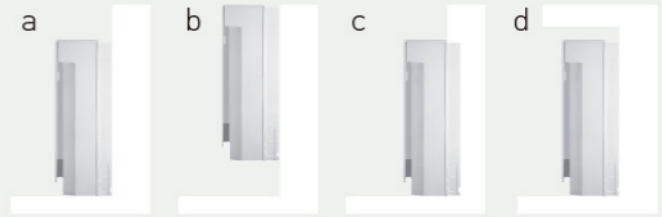

### Double air flow

Double air flow for improved comfort and temperature dispersion: through the top for an efficient operation.

a. Cooling Mode. b. Heating Mode



### Super Quiet operation

When the system reaches its set temperature, the unit will operate at only 20dB(A). Creating a comfortable home is not only by temperature - a quiet atmosphere is also important.



### iF Product Design Awards

The iF Product Design Awards are among the most prestigious awards for product design excellence.

Winning the award thanks to its highly intelligent functionality, the Panasonic Floor console is the ideal air-conditioning system for domestic and commercial applications.

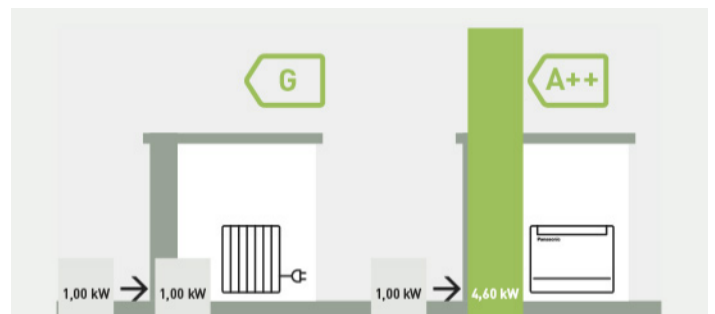

### High energy efficiency class A++

The floor console brings the outdoor heat energy inside. Can provide heat inside even when it is -15°C outside.

\* SCOP on heating mode for Floor console Type KIT-Z25-UFE and KIT-Z35-UFE compared with electrical heaters at +7°C.

Product and accessories



1

2

3

---

**Accessories**

1. CZ-TACG1	Wi-Fi adapter for smart control via Panasonic Comfort Cloud App
2. CZ-CAPRA1	RAC interface adapter for integration into S-Link
3. CZ-RD517C	Wired remote controller for wall-mounted and floor console



Product and accessories



1



2



3



---

**Accessories**

1. CZ-TACG1	Wi-Fi adapter for smart control via Panasonic Comfort Cloud App
2. CZ-CAPRA1	RAC interface adapter for integration into S-Link
3. CZ-RD517C	Wired remote controller for wall-mounted and floor console





Smart & intuitive controls



**Stylish infrared control**

Enjoy innovative design at your fingertips with the stylish and sleek Backlit Sky Controller. Bigger screen and easier to use.

**Voice Control. Words do more than actions**

Boundless control and hands-free help to access all the features of your air-to-air heat pump. Maximising your comfort is now a breeze with our connected air conditioners using the Panasonic Comfort Cloud App and voice control.

\* Google, Android, Google Play and Google Home are trademarks of Google LLC. Amazon, Alexa and all related logos are trademarks of Amazon.com, Inc. or its affiliates. Availability of Voice Assistant services varies depending on Country and Language.

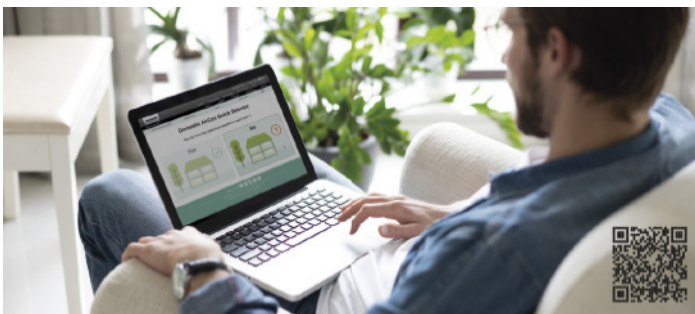

**Domestic AirCon Quick Selector**

This user-friendly online tool for our domestic range allows to choose the best split or multi-split system for each project needs and get the specifications of that particular application.

**Configure in a few steps your multi split system with our online tool and see the capacity of all possible combinations**

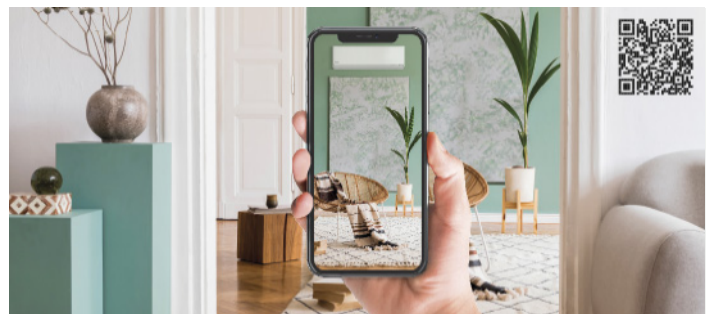

**AR Heat Pump Viewer**

Interested to see how a Panasonic air conditioner looks in your home?

**Try the new Panasonic AR projector, utilising augmented reality!**

Smart & intuitive controls



**Stylish infrared control**

Enjoy innovative design at your fingertips with the stylish and sleek Backlit Sky Controller. Bigger screen and easier to use.

**Voice Control. Words do more than actions**

Boundless control and hands-free help to access all the features of your air-to-air heat pump. Maximising your comfort is now a breeze with our connected air conditioners using the Panasonic Comfort Cloud App and voice control.

\* Google, Android, Google Play and Google Home are trademarks of Google LLC. Amazon, Alexa and all related logos are trademarks of Amazon.com, Inc. or its affiliates. Availability of Voice Assistant services varies depending on Country and Language.



**Domestic AirCon Quick Selector**

This user-friendly online tool for our domestic range allows to choose the best split or multi-split system for each project needs and get the specifications of that particular application.

**Configure in a few steps your multi split system with our online tool and see the capacity of all possible combinations**

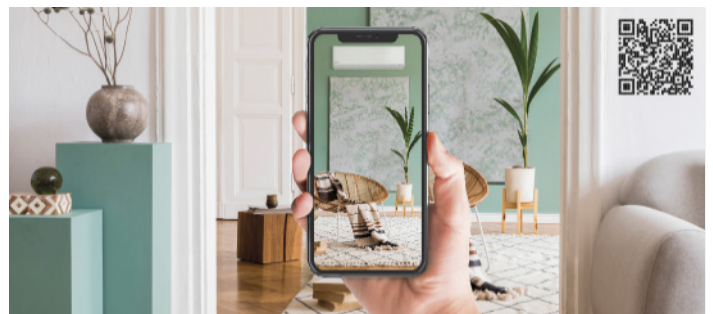

**AR Heat Pump Viewer**

Interested to see how a Panasonic air conditioner looks in your home?

**Try the new Panasonic AR projector, utilising augmented reality!**

# Floor console with nanoe™ X

## Floor Console Inverter+ • R32

## SINGLE PHASE

		5 kW	2.5 kW	3.5 kW
Kit		KIT-Z50-UFE	KIT-Z25-UFE	KIT-Z35-UFE
Cooling capacity (Nominal)	kW	5,00	2,50	3,50
Cooling capacity (Min)	kW	0,90	0,85	0,85
Cooling capacity (Max)	kW	5,70	3,40	3,80
EER (Nominal) (1)	W/W	3,60	4,81	4,07
EER (Min) (1)	W/W	3,53	3,54	3,54
EER (Max) (1)	W/W	3,15	3,78	3,73
SEER (2)		6,70 A++	7,90 A++	8,10 A++
Pdesign (cooling)	kW	5,00	2,50	3,50
Input power cooling (Nominal)	kW	1,39	0,52	0,86
Input power cooling (Min)	kW	0,26	0,24	0,24
Input power cooling (Max)	kW	1,81	0,90	1,02
Annual energy consumption cooling (3)	kWh/a	261,00	111,00	151,00
Heating capacity (Nominal)	kW	5,80	3,40	4,30
Heating capacity (Min)	kW	0,90	0,85	0,85
Heating capacity (Max)	kW	8,10	5,00	6,00
Heating capacity at -7°C	kW	5,03	2,88	3,37
COP (Nominal) (1)	W/W	3,74	4,47	3,98
COP (Min) (1)	W/W	3,46	3,54	3,54
COP (Max) (1)	W/W	3,12	3,70	3,43
SCOP (2)		4,30 A+	4,60 A++	4,60 A++
Pdesign at -10°C	kW	4,40	2,70	3,20
Input power heating (Nominal)	kW	1,55	0,76	1,08
Input power heating (Min)	kW	0,26	0,24	0,24
Input power heating (Max)	kW	2,60	1,35	1,75
Annual energy consumption heating (3)	kWh/a	1433	822	974
Indoor unit		CS-Z50UFEAW	CS-Z25UFEAW	CS-Z35UFEAW
Indoor power source	V	230	230	230
Indoor air flow (Cool)	m³/min	11,6	9,6	9,9
Indoor air flow (Heat)	m³/min	13,2	9,9	10,1
Moisture removal volume	L/h	2,8	1,5	2,0
Indoor sound pressure (Cool -Hi) (4)	dB(A)	44	38	39
Indoor sound pressure (Cool -Hi) (4)	dB(A)	44	38	39
Indoor sound pressure (Cool -Lo) (4)	dB(A)	31	25	26
Indoor sound pressure (Cool -Q-Lo) (4)	dB(A)	27	20	20
Indoor sound pressure (Heat -Hi) (4)	dB(A)	46	38	39
Indoor sound pressure (Heat -Lo) (4)	dB(A)	33	25	26
Indoor sound pressure (Heat -Q-Lo) (4)	dB(A)	29	19	19
Indoor dimension (Height)	mm	600	600	600
Indoor dimension (Width)	mm	750	750	750
Indoor dimension (Depth)	mm	207	207	207
Indoor net weight	kg	13	13	13
nanoe X Generator		Mark 1	Mark 1	Mark 1
Outdoor unit		CU-Z50UBEA	CU-Z25UBEA	CU-Z35UBEA
Outdoor power source	V	230	230	230
Outdoor recommended fuse	A	16	16	16
Outdoor connection indoor / outdoor	mm²	—	—	—
Outdoor air flow (Cool)	m³/min	39,7	28,7	34,3
Outdoor air flow (Heat)	m³/min	38,6	27,2	33,5
Outdoor sound pressure (Cool -Hi) (4)	dB(A)	48	46	48
Outdoor sound pressure (Cool -Hi) (4)	dB(A)	48	46	48
Outdoor sound pressure (Heat -Hi) (4)	dB(A)	48	47	48
Outdoor dimension (Height) (5)	mm	695	542	619
Outdoor dimension (Width) (5)	mm	875	780	824
Outdoor dimension (Depth) (5)	mm	320	289	299
Outdoor net weight	kg	43	33	35
Pipe diameter (Liquid)	Inch (mm)	1/4 (6,35)	1/4 (6,35)	1/4 (6,35)
Pipe diameter (Gas)	Inch (mm)	1/2 (12,70)	3/8 (9,52)	3/8 (9,52)
Pipe length range	m	3 ~ 30	3 ~ 20	3 ~ 20
Elevation difference (in/out) (6)	m	20	15	15
Pipe length for additional gas	m	7,5	7,5	7,5
Additional gas amount	g/m	15	10	10
Refrigerant (R32) / CO2 Eq.	kg / T	1,13 / 0,763	0,88 / 0,594	0,93 / 0,628
Operating range (Cool - Min)	°C	-10	-10	-10
Operating range (Cool - Min)	°C	-10	-10	-10
Operating range (Cool - Max)	°C	+43	+43	+43
Operating range (Heat - Min)	°C	-15	-15	-15
Operating range (Heat - Max)	°C	+24	+24	+24

# Floor console with nanoe™ X

## Floor Console Inverter+ • R32

### SINGLE PHASE

		5 kW	2.5 kW	3.5 kW
Kit		KIT-Z50-UFE	KIT-Z25-UFE	KIT-Z35-UFE
Cooling capacity (Nominal)	kW	5,00	2,50	3,50
Cooling capacity (Min)	kW	0,90	0,85	0,85
Cooling capacity (Max)	kW	5,70	3,40	3,80
EER (Nominal) (1)	W/W	3,60	4,81	4,07
EER (Min) (1)	W/W	3,53	3,54	3,54
EER (Max) (1)	W/W	3,15	3,78	3,73
SEER (2)		6,70 A++	7,90 A++	8,10 A++
Pdesign (cooling)	kW	5,00	2,50	3,50
Input power cooling (Nominal)	kW	1,39	0,52	0,86
Input power cooling (Min)	kW	0,26	0,24	0,24
Input power cooling (Max)	kW	1,81	0,90	1,02
Annual energy consumption cooling (3)	kWh/a	261,00	111,00	151,00
Heating capacity (Nominal)	kW	5,80	3,40	4,30
Heating capacity (Min)	kW	0,90	0,85	0,85
Heating capacity (Max)	kW	8,10	5,00	6,00
Heating capacity at -7°C	kW	5,03	2,88	3,37
COP (Nominal) (1)	W/W	3,74	4,47	3,98
COP (Min) (1)	W/W	3,46	3,54	3,54
COP (Max) (1)	W/W	3,12	3,70	3,43
SCOP (2)		4,30 A+	4,60 A++	4,60 A++
Pdesign at -10°C	kW	4,40	2,70	3,20
Input power heating (Nominal)	kW	1,55	0,76	1,08
Input power heating (Min)	kW	0,26	0,24	0,24
Input power heating (Max)	kW	2,60	1,35	1,75
Annual energy consumption heating (3)	kWh/a	1433	822	974
Indoor unit		CS-Z50UFEAW	CS-Z25UFEAW	CS-Z35UFEAW
Indoor power source	V	230	230	230
Indoor air flow (Cool)	m³/min	11,6	9,6	9,9
Indoor air flow (Heat)	m³/min	13,2	9,9	10,1
Moisture removal volume	L/h	2,8	1,5	2,0
Indoor sound pressure (Cool -Hi) (4)	dB(A)	44	38	39
Indoor sound pressure (Cool -Hi) (4)	dB(A)	44	38	39
Indoor sound pressure (Cool -Lo) (4)	dB(A)	31	25	26
Indoor sound pressure (Cool -Q-Lo) (4)	dB(A)	27	20	20
Indoor sound pressure (Heat -Hi) (4)	dB(A)	46	38	39
Indoor sound pressure (Heat -Lo) (4)	dB(A)	33	25	26
Indoor sound pressure (Heat -Q-Lo) (4)	dB(A)	29	19	19
Indoor dimension (Height)	mm	600	600	600
Indoor dimension (Width)	mm	750	750	750
Indoor dimension (Depth)	mm	207	207	207
Indoor net weight	kg	13	13	13
nanoe X Generator		Mark 1	Mark 1	Mark 1
Outdoor unit		CU-Z50UBEA	CU-Z25UBEA	CU-Z35UBEA
Outdoor power source	V	230	230	230
Outdoor recommended fuse	A	16	16	16
Outdoor connection indoor / outdoor	mm²	—	—	—
Outdoor air flow (Cool)	m³/min	39,7	28,7	34,3
Outdoor air flow (Heat)	m³/min	38,6	27,2	33,5
Outdoor sound pressure (Cool -Hi) (4)	dB(A)	48	46	48
Outdoor sound pressure (Cool -Hi) (4)	dB(A)	48	46	48
Outdoor sound pressure (Heat -Hi) (4)	dB(A)	48	47	48
Outdoor dimension (Height) (5)	mm	695	542	619
Outdoor dimension (Width) (5)	mm	875	780	824
Outdoor dimension (Depth) (5)	mm	320	289	299
Outdoor net weight	kg	43	33	35
Pipe diameter (Liquid)	Inch (mm)	1/4 (6,35)	1/4 (6,35)	1/4 (6,35)
Pipe diameter (Gas)	Inch (mm)	1/2 (12,70)	3/8 (9,52)	3/8 (9,52)
Pipe length range	m	3 ~ 30	3 ~ 20	3 ~ 20
Elevation difference (in/out) (6)	m	20	15	15
Pipe length for additional gas	m	7,5	7,5	7,5
Additional gas amount	g/m	15	10	10
Refrigerant (R32) / CO2 Eq.	kg / T	1,13 / 0,763	0,88 / 0,594	0,93 / 0,628
Operating range (Cool - Min)	°C	-10	-10	-10
Operating range (Cool - Min)	°C	-10	-10	-10
Operating range (Cool - Max)	°C	+43	+43	+43
Operating range (Heat - Min)	°C	-15	-15	-15
Operating range (Heat - Max)	°C	+24	+24	+24

Dimensions

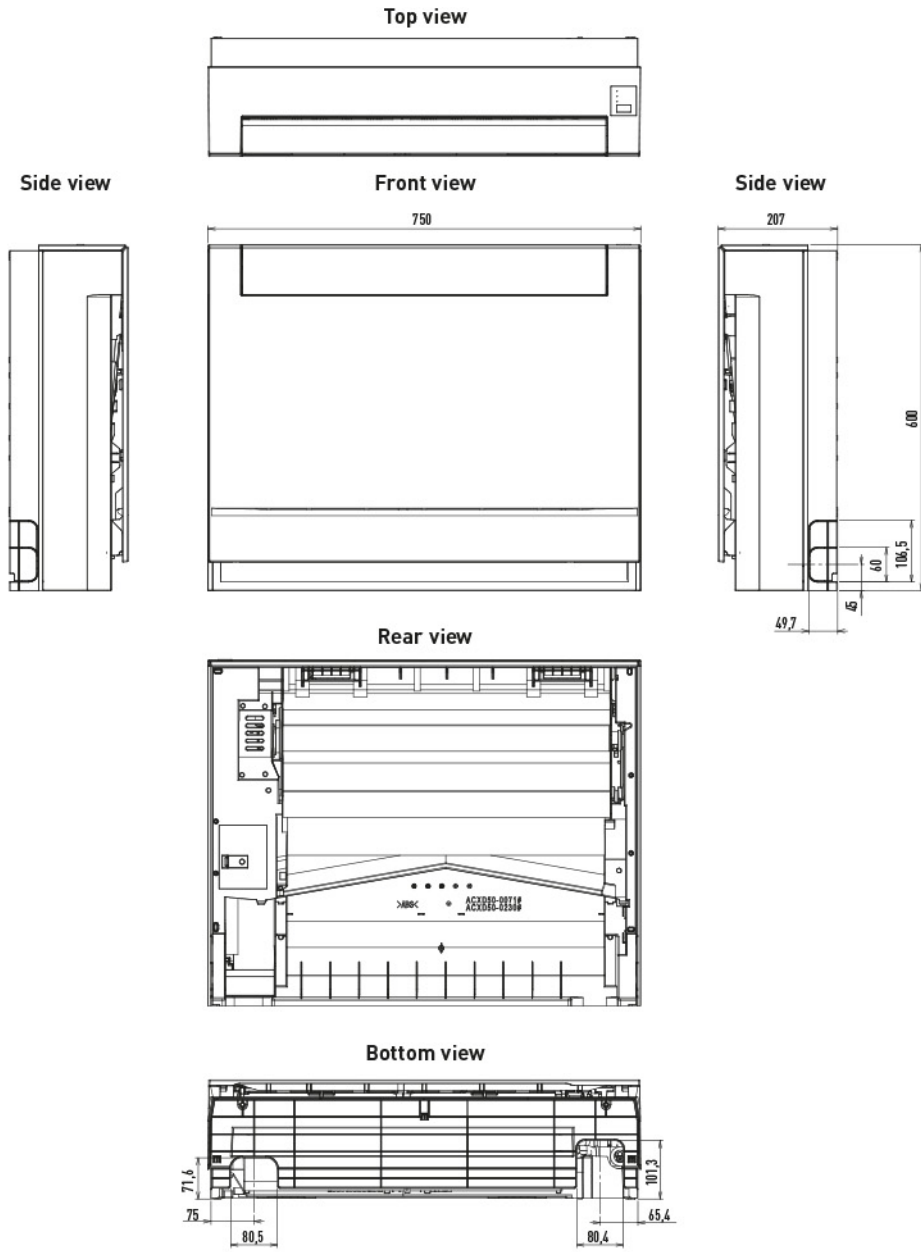

CU-Z25UBEA

CU-Z35UBEA

CU-Z50UBEA

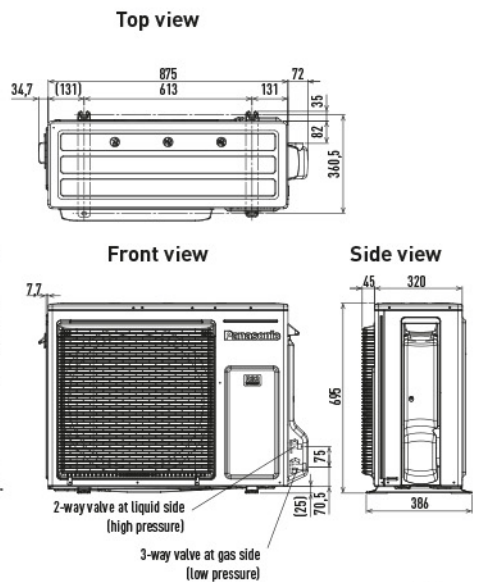
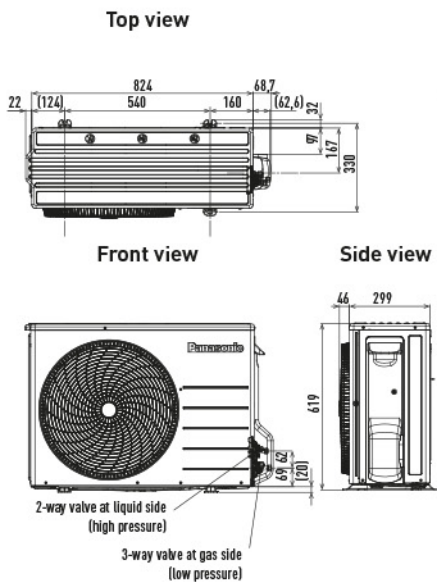
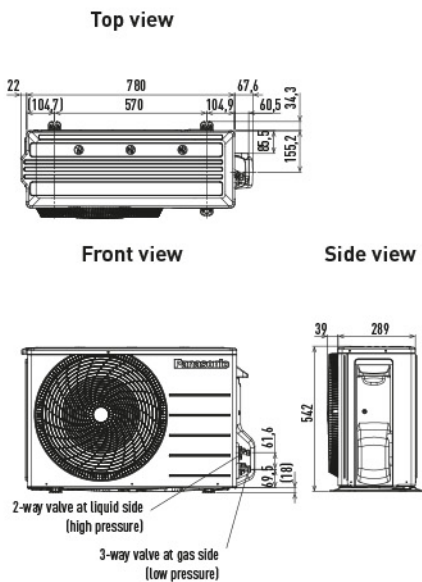

Unit: mm

## Wiring diagrams

Floor console kits 1x1

Indoor unit



Infrared remote controller (included in the delivery)



Outdoor unit



Single phase  
Power supply  
230 V / 50 Hz

### Single phase

Indoor unit	Power supply	Recommended fuse	Power supply cable	Connection indoor / outdoor	Outdoor unit
CS-Z25UFEAW	230 V (outdoor)	16 A	3 x 1,5 mm <sup>2</sup>	4 x 1,5 mm <sup>2</sup>	CU-Z25UBEA
CS-Z35UFEAW	230 V (outdoor)	16 A	3 x 1,5 mm <sup>2</sup>	4 x 1,5 mm <sup>2</sup>	CU-Z35UBEA
CS-Z50UFEAW	230 V (outdoor)	16 A	3 x 2,5 mm <sup>2</sup>	4 x 2,5 mm <sup>2</sup>	CU-Z50UBEA